

Data Sheet

R-Series V RP5 Analog

Magnetostrictive Linear Position Sensors

- Direct analog output, position + speed
- Dual magnet position measurement
- Field adjustments and diagnostics using the new TempoLink® smart assistant



V
DIE NEUE GENERATION

MEASURING TECHNOLOGY

The absolute, linear position sensors provided by Temposonics rely on the company's proprietary magnetostrictive technology, which can determine position with a high level of precision and robustness. Each Temposonics position sensor consists of a ferromagnetic waveguide, a position magnet, a strain pulse converter and supporting electronics. The magnet, connected to the object in motion in the application, generates a magnetic field at its location on the waveguide. A short current pulse is applied to the waveguide. This creates a momentary radial magnetic field and torsional strain on the waveguide. The momentary interaction of the magnetic fields releases a torsional strain pulse that propagates the length of the waveguide. When the ultrasonic wave reaches the end of the waveguide it is converted into an electrical signal. Since the speed of the ultrasonic wave in the waveguide is precisely known, the time required to receive the return signal can be converted into a linear position measurement with both high accuracy and repeatability.

R-SERIES V Analog

Temposonics® R-Series V brings very powerful sensor performance to meet the many demands of your application. The R-Series V is the long term solution for harsh environments that have high levels of shock and vibration. Sensor models with analog outputs (voltage/current) have options for one or two position magnets, and for single or dual output channels.

When the R-Series V Analog sensor is ordered with a single output channel for one position magnet, the output will be the measured position value presented in either voltage or current.

When the sensor is ordered with dual output channels the second output can be configured to report the position of the second magnet or the reverse position or velocity of one magnet or the temperature inside of the electronics housing. Other configurations can be adjusted using the TempoLink smart assistant.

With many outstanding features the R-Series V sensors are fit for a very broad range of applications.

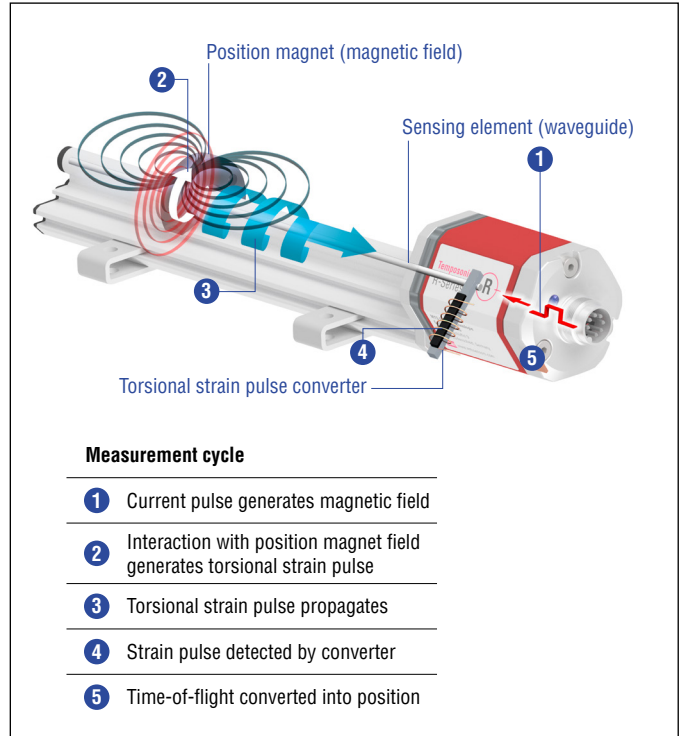

Fig. 1: Time-of-flight based magnetostrictive position sensing principle

TempoLink® YOUR SMART ASSISTANT

The TempoLink® smart assistant is an accessory for the R-Series V family of sensors that supports setup and diagnostics. For the R-Series V Analog model, it enables the adjustment of parameters like the output values for the zero and span setpoints and their locations on the sensor. For diagnostics and analysis of operational data the R-Series V sensors continuously track values such as total distance traveled by the position magnet, internal temperature of the sensor and the quality of the position signal. This additional information can be read out via TempoLink® even while the sensor remains operational in the application.

The smart assistant is connected to the sensor via the power connection, which now adds bidirectional communication for setup and diagnostics. The TempoLink® smart assistant is operated using a graphical user-interface that will be displayed on your smartphone, tablet, laptop or PC. Just connect your Wi-Fi-enabled device to TempoLink® Wi-Fi access point and go to the website URL for the user-interface.



Fig. 2: R-Series V sensor with TempoLink® smart assistant

TECHNICAL DATA

Output							
Analog	Voltage: 0...10/10...0/-10...+10/+10...-10 VDC (min. controller load > 5 kΩ) Current: 4(0)...20/20...4(0) mA (min./max. load 0/500 Ω)						
Measured output variables	Position for one or two position magnets. Position + speed (without direction) or velocity (with direction) for one position magnet. Position for one position magnet + temperature inside the sensor electronics housing						
Measurement parameters							
Position measurement							
Null/Span adjustment	100 % of electrical stroke						
Resolution	16 bit (internal resolution 0.1 μm)						
Linearity deviation ¹	< ±0.01 % F.S. (minimum ±50 μm)						
Repeatability	< ±0.001 % F.S. (minimum ±1 μm)						
Hysteresis	< 4 μm						
Update time	Stroke length	≤ 200 mm	≤ 350 mm	≤ 1200 mm	≤ 2400 mm	≤ 4800 mm	≤ 6350 mm
	Update time	0.25 ms	0.333 ms	0.5 ms	1.0 ms	2.0 ms	5.0 ms
Velocity measurement							
Range	0.01...10 m/s or 1...400 in./s						
Deviation	≤ 0.05 %						
Resolution	16 bit (minimum 0.01 mm/s)						
Operating conditions							
Operating temperature	-40...+85 °C (-40...+185 °F)						
Humidity	90 % relative humidity, no condensation						
Temperature coefficient	< 30 ppm/K						
Ingress protection	IP67 (connectors correctly fitted)						
Shock test	150 g/11 ms, IEC standard 60068-2-27						
Vibration test	30 g/10...2000 Hz, IEC standard 60068-2-6 (excluding resonant frequencies)						
EMC test	Electromagnetic emission according to EN 61000-6-3						
	Electromagnetic immunity according to EN 61000-6-2 The sensor meets the requirements of the EC directives and is marked with CE						
Magnet movement velocity	Magnet slider: Max. 10 m/s; U-magnet: Any; block magnet: Any						
Design / Material							
Sensor electronics housing	Aluminum (painted), zinc die cast						
Sensor profile	Aluminum						
Stroke length	25...6350 mm (1...250 in.)						
Mechanical mounting							
Mounting position	Any						
Mounting instruction	Please consult the technical drawings on page 4						
Electrical connection							
Connection type	1 × M16 male connectors (6 pin) or cable outlet						
Operating voltage	12...30 VDC ±20 % (9.6...36 VDC)						
Power consumption	< 3.25 W						
Dielectric strength	500 VDC (DC ground to machine ground)						
Polarity protection	Up to -36 VDC						
Overvoltage protection	Up to 36 VDC						

1/ With position magnet # 251 416-2

TECHNICAL DRAWING

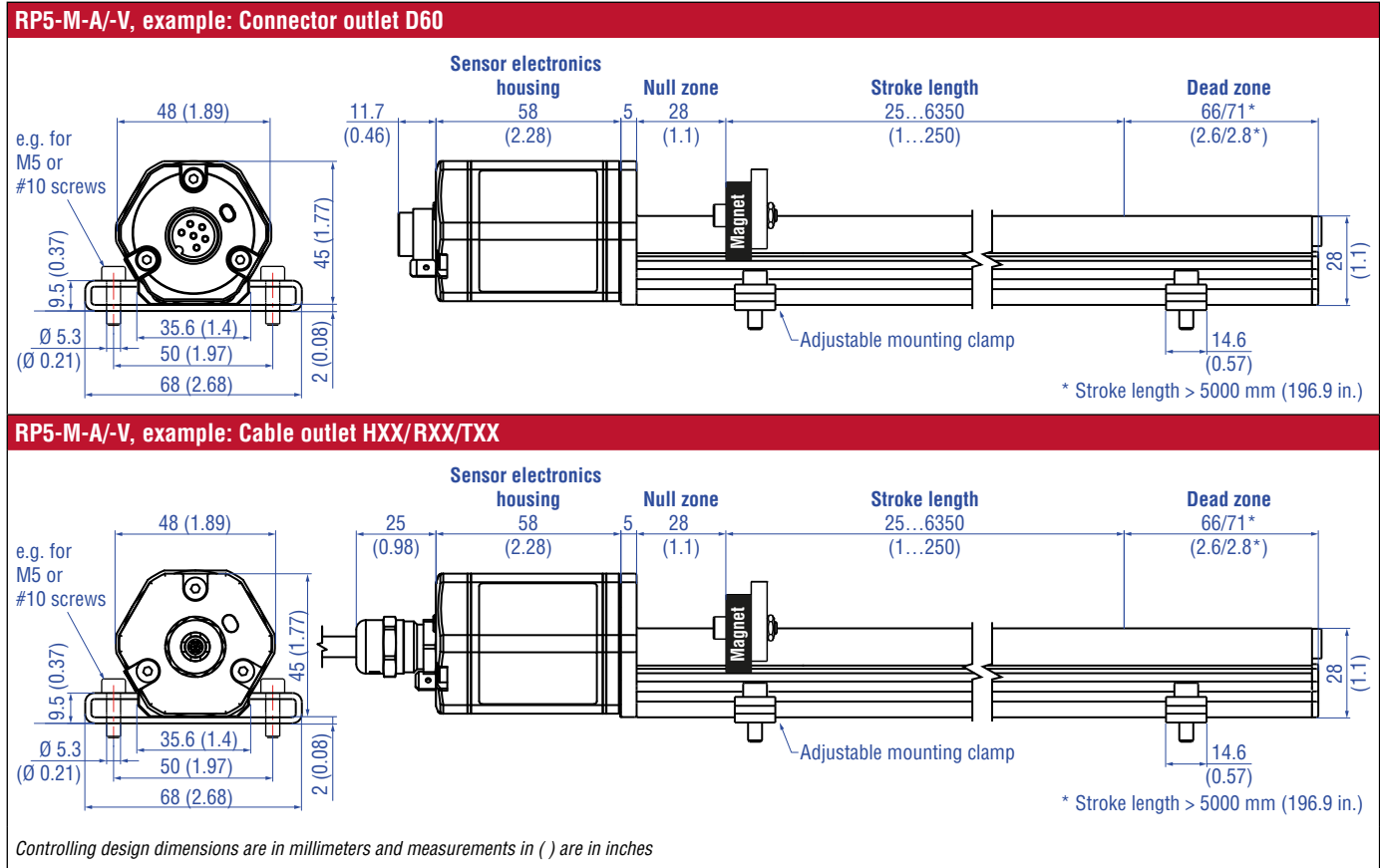

Fig. 3: Temposonics® RP5 with U-magnet

CONNECTOR WIRING

D60			
Signal + power supply			
M16 male connector	Output	Pin	Function
<p>View on sensor</p>	1	1	Position (magnet 1)
		2	Signal Ground
	2*	3	Position (magnet 2) or reverse position (magnet 1) or speed or velocity (magnet 1) or temperature inside the sensor electronics housing
		4	Signal Ground
		5	+12...30 VDC (±20 %)
		6	DC Ground (0 V)
* order dependent			

Fig. 4: Connector wiring D60

HXX / RXX / TXX			
Signal + power supply			
Cable	Output	Color	Function
	1	GY	Position (magnet 1)
		PK	Signal Ground
	2*	YE	Position (magnet 2) or reverse position (magnet 1) or speed or velocity (magnet 1) or temperature inside the sensor electronics housing
		GN	Signal Ground
		BN	+12...30 VDC (±20 %)
		WH	DC Ground (0 V)
	* order dependent		
For cable type TXX, the extra red & blue wires are not used.			

Fig. 5: Connector wiring for cable outlet

FREQUENTLY ORDERED ACCESSORIES – Additional options available in our [Accessories Guide](#) 551444



Position magnets

<p>Magnet slider S, joint at top Part no. 252 182</p> <p>Material: GRP, magnet hard ferrite Weight: Approx. 35 g Operating temperature: -40...+85 °C (-40...+185 °F)</p>	<p>Magnet slider V, joint at front Part no. 252 184</p> <p>Material: GRP, magnet hard ferrite Weight: Approx. 35 g Operating temperature: -40...+85 °C (-40...+185 °F)</p>	<p>Magnet slider N longer ball-joint arm Part no. 252 183</p> <p>Material: GRP, magnet hard ferrite Weight: Approx. 35 g Operating temperature: -40...+85 °C (-40...+185 °F)</p>	<p>Magnet slider G, backlash free Part no. 253 421</p> <p>Material: GRP, magnet hard ferrite Weight: Approx. 25 g Operating temperature: -40...+85 °C (-40...+185 °F)</p>

Position magnets

Mounting accessories

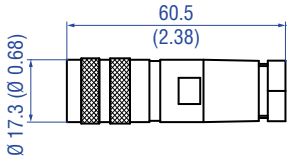
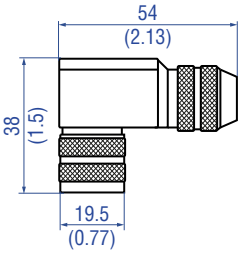
<p>U-magnet OD33 Part no. 251 416-2</p> <p>Material: PA ferrite GF20 Weight: Approx. 11 g Surface pressure: Max. 40 N/mm² Fastening torque for M4 screws: 1 Nm Operating temperature: -40...+105 °C (-40...+221 °F)</p>	<p>Block magnet L Part no. 403 448</p> <p>Material: Plastic carrier with hard ferrite magnet Weight: Approx. 20 g Fastening torque for M4 screws: 1 Nm Operating temperature: -40...+75 °C (-40...+167 °F)</p> <p>This magnet may influence the sensor performance specifications for some applications.</p>	<p>Mounting clamp Part no. 400 802</p> <p>Material: Stainless steel (AISI 304)</p>	<p>T-nut Part no. 401 602</p> <p>Fastening torque for M5 screw: 4.5 Nm</p>

Cable connectors*		Programming tools	
			
M16 female connector (6 pin), straight Part no. 370 423	M16 female connector (6 pin), angled Part no. 370 460	TempoLink® kit for Temposonics® R-Series V Part no. TL-1-0-AD60 (for D60) Part no. TL-1-0-AS00 (for cable output)	Hand programmer for analog output Part no. 253 124
Material: Zinc nickel plated Termination: Solder Cable Ø: 6...8 mm (0.24...0.31 in.) Operating temperature: -40...+100 °C (-40...+212 °F) Ingress protection: IP65/IP67 (correctly fitted) Fastening torque: 0.6 Nm	Material: Zinc nickel plated Termination: Solder Cable Ø: 6...8 mm (0.24...0.31 in.) Wire: 0.75 mm ² (20 AWG) Operating temperature: -40...+95 °C (-40...+203 °F) Ingress protection: IP67 (correctly fitted) Fastening torque: 0.6 Nm	<ul style="list-style-type: none"> • Connect wirelessly via Wi-Fi enabled device or via USB with the diagnostic tool • Simple connectivity to the sensor via 24 VDC power line (permissible cable length: 30 m) • User friendly interface for mobile devices and desktop computers • See data sheet "TempoLink smart assistant" (document part no.: 552070) for further information 	Easy teach-in-setups of stroke length and direction on desired zero / span positions. For sensors with 1 magnet.

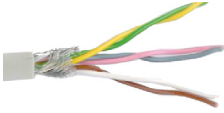
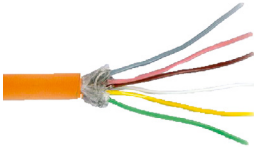
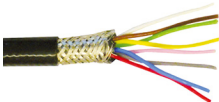
Programming tool	Cables		
			
Cabinet programmer for analog output Part no. 253 408	PVC cable Part no. 530 032	PUR cable Part no. 530 052	Teflon® cable Part no. 530 112
Features snap-in mounting on standard DIN rail (35 mm). This programmer can be permanently mounted in a control cabinet and includes a program/run switch. For sensors with 1 magnet.	Material: PVC jacket; gray Features: Twisted pair, shielded, flexible Cable Ø: 6 mm (0.23 in.) Cross section: 3 × 2 × 0.14 mm ² Bending radius: 10 × D (fixed installation) Operating temperature: -40...+105 °C (-40...+221 °F)	Material: PUR jacket; orange Features: Twisted pair, shielded, highly flexible, halogen free, suitable for drag chains, mostly oil & flame resistant Cable Ø: 6.4 mm (0.25 in.) Cross section: 3 × 2 × 0.25 mm ² Bending radius: 5 × D (fixed installation) Operating temperature: -30...+80 °C (-22...+176 °F)	Material: Teflon® jacket; black Features: Twisted pair, shielded, flexible, high thermal resistance, mostly oil & acid resistant Cable Ø: 7.6 mm (0.3 in.) Cross section: 4 × 2 × 0.25 mm ² Bending radius: 8 – 10 × D (fixed installation) Operating temperature: -100...+180 °C (-148...+356 °F)

* / Follow the manufacturer's mounting instructions

Controlling design dimensions are in millimeters and measurements in () are in inches

Extension cables



PVC cable with M16 female connector (6 pin), straight – pigtail

PVC cable (part no. 530 032) with M16 female connector, straight (part no. 370 423)

Order code:
MTS-A-370423-xxxx-530032-0
(where xxxx is the cable length in centimeters (e.g. code: 0150))



PUR cable with M16 female connector (6 pin), straight – pigtail

PUR cable (part no. 530 052) with M16 female connector, straight (part no. 370 423)

Order code:
MTS-A-370423-xxxx-530052-0
(where xxxx is the cable length in centimeters (e.g. code: 0150))



Teflon® cable with M16 female connector (6 pin), straight – pigtail

Teflon® cable (part no. 530 112) with M16 female connector, straight (part no. 370 423)

Order code:
MTS-A-370423-xxxx-530112-0
(where xxxx is the cable length in centimeters (e.g. code: 0150))

Standard cable lengths

Meters	Feet	Code
1.5	5	0150
2	6.6	0200
4.6	15	0460
5	16.4	0500
7.6	25	0760
10	32.8	1000
15.2	50	1520

For additional extension cables reference the accessory catalog (551444), [page 41](#) for industrial sensors.

ORDER CODE

1	2	3	4	5	6	7	8	9	10	11	12	13	14	15	16	17	18	19	20	21	22	23	
R	P	5								0					1								
a			b	c	d					e	f			g	h	i	j	k	l optional				

a	Sensor model		
R	P	5	Profile

b	Design
G	Magnet slider backlash free (part no. 253 421)
L	Block magnet L (part no. 403 448)
M	U-magnet OD33 (part no. 251 416-2)
N	Magnet slider longer ball-jointed arm (part no. 252 183)
O	No position magnet
S	Magnet slider joint at top (part no. 252 182)
V	Magnet slider joint at front (part no. 252 184)

c	Mechanical options
A	Standard
V	Fluorelastomer seals for the sensor electronics housing

d	Stroke length				
X	X	X	X	M	0025...6350 mm
Standard stroke length (mm)		Ordering steps			
25... 500 mm		25 mm			
500...2500 mm		50 mm			
2500...5000 mm		100 mm			
5000...6350 mm		250 mm			
X	X	X	X	U	001.0...250.0 in.
Standard stroke length (in.)		Ordering steps			
1... 20 in.		1.0 in.			
20...100 in.		2.0 in.			
100...200 in.		4.0 in.			
200...250 in.		10.0 in.			
Non-standard stroke lengths are available; must be encoded in 5 mm/0.1 in. increments.					

e	Number of magnets	
0	X	01...02 Position(s) (1...2 magnet(s))

f	Connection type		
D	6	0	M16 male connector (6 pin)
H	X	X	XX m PUR cable (part no. 530 052) H01...H30 (1...30 m/3...99 ft.) See "Frequently ordered accessories" for cable specifications
R	X	X	XX m PVC cable (part no. 530 032) R01...R30 (1...30 m/3...99 ft.) See "Frequently ordered accessories" for cable specifications
T	X	X	XX m Teflon® cable (part no. 530 112) T01...T30 (1...30 m/3...99 ft.) See "Frequently ordered accessories" for cable specifications
*/ Encode in meters if using metric stroke length. Encode in feet if using US customary stroke length			

g	System
1	Standard

h	Output
A	Current
V	Voltage

i	Function
1	Position (1 or 2 magnets/outputs)
2	Position and speed (1 magnet and 2 outputs)
3	Position and velocity (1 magnet and 2 outputs)
4	Position and reverse position (1 magnet and 2 outputs)
5	Position and temperature inside the sensor electronics housing (1 magnet and 2 outputs)
6	Differential (2 magnets and 1 output)

j	Options
0	Standard
3	Over range output mode

k	Output range
0	0...10 VDC or 4...20 mA
1	10...0 VDC or 20...4 mA
2	-10...+10 VDC or 0...20 mA
3	+10...-10 VDC or 20...0 mA
V	0...10 VDC for position, -10...+10 VDC for velocity

I Max speed or velocity value
(optional: use when **i** "Function" is 2 or 3)

For metric stroke lengths encode speed or velocity in m/s for the values 0.01 to 9.99 m/s (001...999)
For US customary stroke lengths encode speed or velocity in inches/s for the values 1 to 400 in./s (001...400)

Use the codes (00E) for 0.025 m/s, and (A00) for 10.0 m/s to provide backwards compatibility for these predecessor models of the R-Series.

NOTICE

- For RP5, the magnet selected in **b** "Design" is included in the scope of delivery. Specify the number of magnets for your application. For multi-position measurements with more than 1 magnet order the other magnets separately.
- The number of magnets is limited by the stroke length. The minimum allowed distance between magnets (i.e. front face of one to the front face of the next one) is 75 mm (3 in.).
- Use magnets of the same type for multi-position measurement, e.g. 2 × U-magnet (part no. 251 416-2).

DELIVERY



- Sensor
 - Position magnet (not valid for RP5 with design »0«)
 - 2 mounting clamps up to 1250 mm (50 in.) stroke length
+ 1 mounting clamp for each 500 mm (20 in.) additional stroke length
- Accessories have to be ordered separately.

Manuals, Software & 3D Models available at:
www.temposonics.com

GLOSSARY

A

Analog output
For a sensor with analog output, the measured value is output as an analog voltage signal or current signal.

D

Differential
For differential measurement, the distance between the two position magnets is output as a value.

M

Max speed or velocity value
For speed or velocity, the output value generated is scaled based on the maximum speed or velocity value indicated in the order code.

Measuring direction

- Forward: Values increasing from sensor electronics housing to rod end/profile end
- Reverse: Values decreasing from sensor electronics housing to rod end/profile end

Multi-position measurement
During the measurement cycle, the positions of every magnet on the sensor are simultaneously reported. The velocity or speed are continuously calculated based on these changing position values as the magnets are moved.

O

Over range output mode
When enabled this mode allows the position output values to continue to increase or decrease when the magnet travels beyond the active stroke range.

R

Resolution
The sensor precisely measures time to provide the position measurement. For the analog output the measured time value is converted into an analog voltage signal or current signal using a high-performance Digital to Analog Converter (DAC) having 16 bits of resolution.

S

Speed
The output value for speed indicates how fast the position magnet is being moved, independent of the measuring direction. (→ Velocity)

T

Temperature inside the sensor electronics housing
The temperature inside the sensor electronics housing is reported as an analog voltage signal or current signal. For each output range, the 0 % output value has the factory default setpoint at -40 °C, and the 100 % output value has the default setpoint at +100 °C.
Note: a dedicated temperature chip is used for the output signal and its values may vary from those reported on the TempoLink application screen.

V

Velocity
The output value for velocity indicates how fast the position magnet is being moved, and in which direction. (→ Speed)



Temposonics

AN AMPHENOL COMPANY

UNITED STATES
Temposonics, LLC
Americas & APAC Region
3001 Sheldon Drive
Cary, N.C. 27513
Phone: +1 919 677-0100
E-mail: info.us@temposonics.com

GERMANY
Temposonics
GmbH & Co. KG
EMEA Region & India
Auf dem Schüffel 9
58513 Lüdenscheid
Phone: +49 2351 9587-0
E-mail: info.de@temposonics.com

ITALY
Branch Office
Phone: +39 030 988 3819
E-mail: info.it@temposonics.com

FRANCE
Branch Office
Phone: +33 6 14 060 728
E-mail: info.fr@temposonics.com

UK
Branch Office
Phone: +44 79 44 15 03 00
E-mail: info.uk@temposonics.com

SCANDINAVIA
Branch Office
Phone: + 46 70 29 91 281
E-mail: info.sca@temposonics.com

CHINA
Branch Office
Phone: +86 21 2415 1000 / 2415 1001
E-mail: info.cn@temposonics.com

JAPAN
Branch Office
Phone: +81 3 6416 1063
E-mail: info.jp@temposonics.com

Document Part Number:
552062 Rev B (EN) 05/2021



temposonics.com

© 2021 Temposonics, LLC – all rights reserved. Temposonics, LLC and Temposonics GmbH & Co. KG are subsidiaries of Amphenol Corporation. Except for any third party marks for which attribution is provided herein, the company names and product names used in this document may be the registered trademarks or unregistered trademarks of Temposonics, LLC or Temposonics GmbH & Co. KG. Detailed trademark ownership information is available at www.temposonics.com/trademarkownership.